

## INSTALLATION INSTRUCTIONS



### ELECTRICAL SHOCK HAZARD

**READ, UNDERSTAND, and FOLLOW** these instructions before installing the equipment.

### WARNING

Disconnect the Electrical supply power at the service panel (fuse or circuit breaker box). Failure to do so could result in serious injury or death. Only qualified electricians should install this fixture and the installation MUST conform to the Electrical Code and all local codes and ordinances. Ensure that only proper tools, materials, and equipment are used to complete the installation.

### SAFETY

- Proper grounding is required to ensure personal safety.
- Fixture should be mounted in locations where unauthorized personnel will not readily subject it to tampering.
- Do not use this equipment for anything other than its intended purpose.
- Servicing this equipment should be performed by qualified service personnel.
- Save these instructions.
- This equipment has been tested and found to comply with the limits for a Class B digital device, pursuant to part 15 of the FCC Rules. These limits are designed to provide reasonable protection against harmful interference in a residential installation. This equipment generates, uses, and can radiate radio frequency energy and, if not installed and used in accordance with the instructions, may cause harmful interference to radio communications.
- Changes or modifications to this unit not expressly approved by the party responsible for compliance Could void the user authority to operate the equipment.
- **MIN 90 °C SUPPLY CONDUCTOR**

### INSTALLATION

- Open the fixture by loosening the two screws on the side and swing open the lens assembly. Be sure to disconnect connection terminal.
- Prepare the back box for mounting by attaching gasket to bottom shell and drilling the appropriate holes.
- Mount Wall Pack at desired location. Ensure that the top, both sides and the mounting holes that are touching the wall are sealed with silicone.
- Remove required conduit entry plug and use appropriate waterproof connection to bring wiring into the Wall Pack. Make appropriate wiring connections as per the wiring diagram.
- Reconnect the connection terminals and close the lens assembly and secure the two side screws

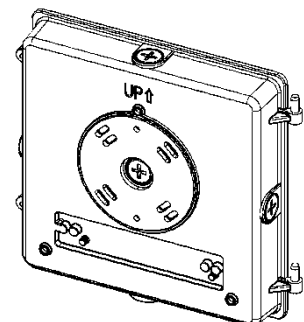
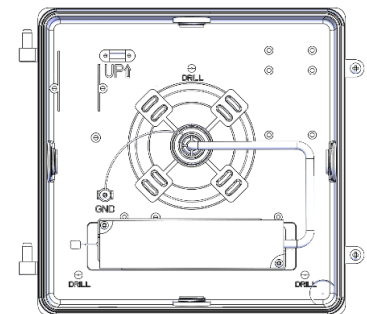
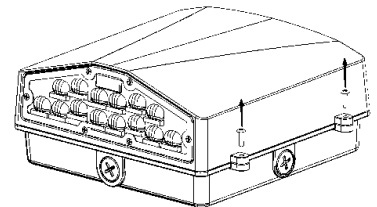

**INSTALLATION INSTRUCTIONS**

**CCT & LUMEN SELECTABLE SWITCHES**

- CCT selectable switch is included in every luminaire. It is accessed inside during installation. The switch can be set to 3000K, 4000K, and 5000K CCT. **4000K is default.**

CCT Correlation		
WW	CW/WW	CW
3000K	4000K	5000K

- Lumen selectable switch is included in every luminaire. It is accessed inside during installation. Lumens vary depending on model. **Max lumen setting is default.**

	H	M	L
<b>WPF1-LED25A15:</b>	15W	20W	25W
<b>WPF2-LED55A33:</b>	33W	44W	55W
<b>WPS1-LED30A18:</b>	18W	24W	30W
<b>WPS2-LED70A42:</b>	42W	56W	70W

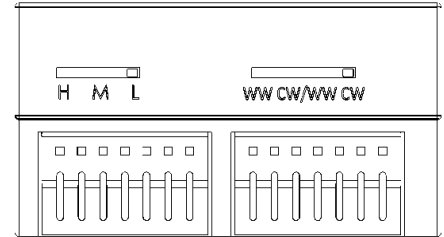

**WIRING**

- Check that the line voltage is correct.
- Connect fixture **GROUND** (green) wire to power supply **GROUND** (green) wire.
- Connect fixture **WHITE** wire to power supply **NEUTRAL** wire.
- Connect fixture **BLACK** wire to power supply **LINE** wire.
- The fixture includes 0-10V dimming functionality, connect **GREY** and **VIOLET** wires to a 0-10V dimming controller (optional).

