

The AWL2-LED80 is a wall pack with an adjustable head that can be aimed straight down for dark sky requirements or aimed out to deliver the light where required.



APPLICATIONS

Ideal for use on outdoor walls along perimeters of buildings, townhouses, condominiums, schools.

Project	
Type	
Date	
Notes	

SPECIFICATIONS

Construction

Die cast aluminum housing with tamperproof stainless steel hardware. Clear tempered glass lens with a gasket. There are 6 conduit entries. The unit has a unique hinge assembly for easy installation and a leveling bubble on the back box for proper alignment.

LED configuration

The AWL2-LED80 has two LED Chips On Board (COBs) that deliver 8 287 lumens. The LEDs have a color temperature of 5000K as standard. 3000K and 4000K also available. The LEDs have a CRI of greater than 70 and an operating temperature range of -40°C to +40°C.

Adjustable head

The fixture can be aimed 0° - 90° delivering more lumens on the ground where needed.

Electrical

Total system wattage of the unit is 80W. The standard unit has a high efficiency driver that operates at 120V - 277V.

Finish

Standard finish is Bronze. Please consult factory for custom color.

Accessories

Visor, Polycarbonate Lens, Wire Guard, Photocontrol, On/Off Sensor and 0 - 10V Dimmable Smart Sensor.

Equivalent to	up to 250W MH
Input Watts	80W
Lumens	8 287 lumens
Efficiency	104 lumens per watt

Operating Temperature	-40°C to +40°C
Certification	cUL, IP65 meets LM79, LM80
LED life	100,000 hours
Colour Temperature	5000K (standard) 4000K, 3000K (option)
Warranty	5 Years
Total Harmonic Distortion	20%
Power Factor	0.9

DIMENSIONS

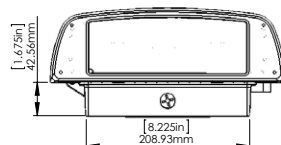
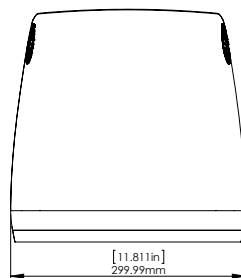
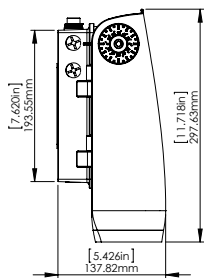

Shown with optional Motion Sensor



INSTALLATION INFORMATION

1. Open fixture, mount back box to junction box



2. Rest fixture onto hinges and connect wires



3. Reattach fixture to back box

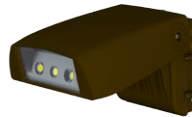

4. Use set screw to adjust fixture to desired angle



ACCESSORIES

Visor (V), Wire Guard (WG), Polycarbonate lens (PCL)

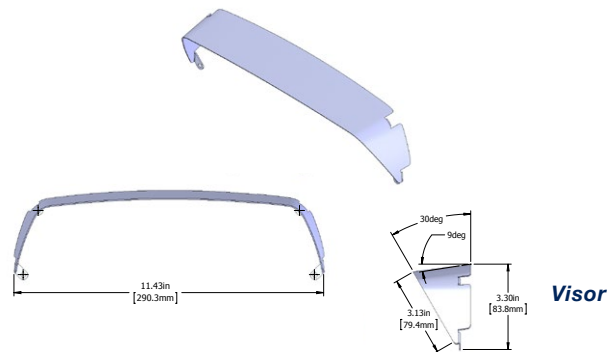
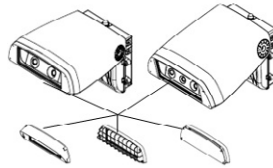

Visor

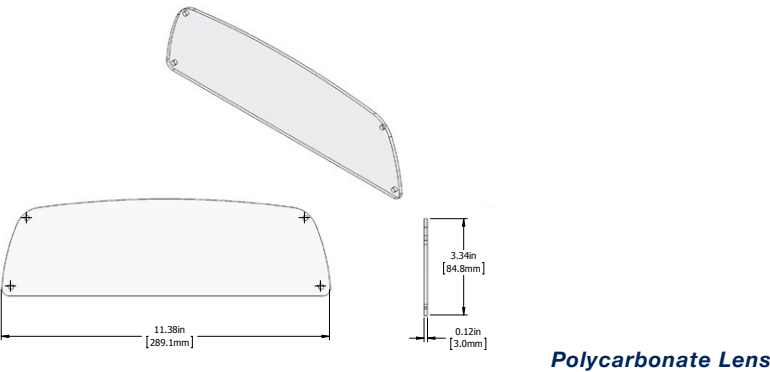

Polycarbonate Lens

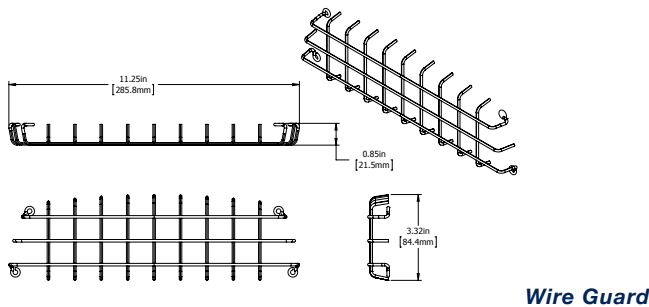

Wire Guard

MS180 DIM 0 - 10V Dimmable Smart Sensor (DMS), MS180S On/Off sensor (SMS)

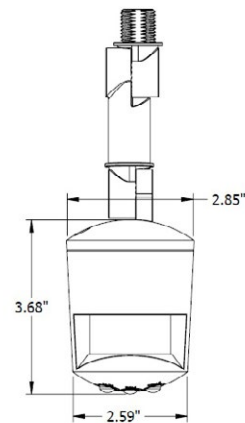

Dimmable Smart Sensor

The MS180DIM is a fully adjustable, dimmable smart sensor that allows you to provide reduced light levels as low as 10% when no motion is detected.

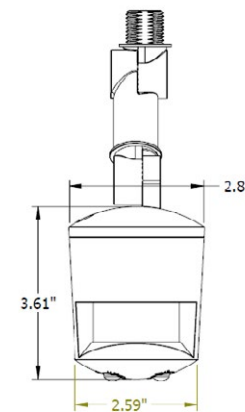

On/Off Sensor

The MS180S is a fully adjustable motion sensor that can be set for dusk to dawn operation or other custom applications.

Contact us to learn more.

PHOTOMETRIC DATA

IESNA:LM-63-2002
[TEST]
[TESTLAB]
[TESTDATE] 2/10/2015
[ISSUE DATE] 2/10/2015
[LUMCAT] AWL2-LED80-B-5K-BRZ
[LUMINAIRE] AWL2 SERIES

CHARACTERISTICS

IES Classification	Type II
Longitudinal Classification	Very Short
Lumens Per Lamp	N.A. (absolute)
Total Lamp Lumens	N.A. (absolute)
Luminaire Lumens	7467
Downward Total Efficiency	N.A. (absolute)
Total Luminaire Efficiency	N.A. (absolute)
Luminaire Efficacy Rating (LER)	97
Total Luminaire Watts	77.31
Ballast Factor	1.00
Upward Waste Light Ratio	0.00
Maximum Candela	4389.723
Maximum Candela Angle	337.5H 19V
Maximum Candela (<90 Degrees Vertical)	4389.723
Maximum Candela Angle (<90 Degrees Vertical)	337.5H 19V
Maximum Candela At 90 Degrees Vertical	6.142 (0.1% Luminaire Lumens)
Maximum Candela from 80 to <90 Degrees Vertical	12.987 (0.2% Luminaire Lumens)
Cutoff Classification (deprecated)	N.A. (absolute)

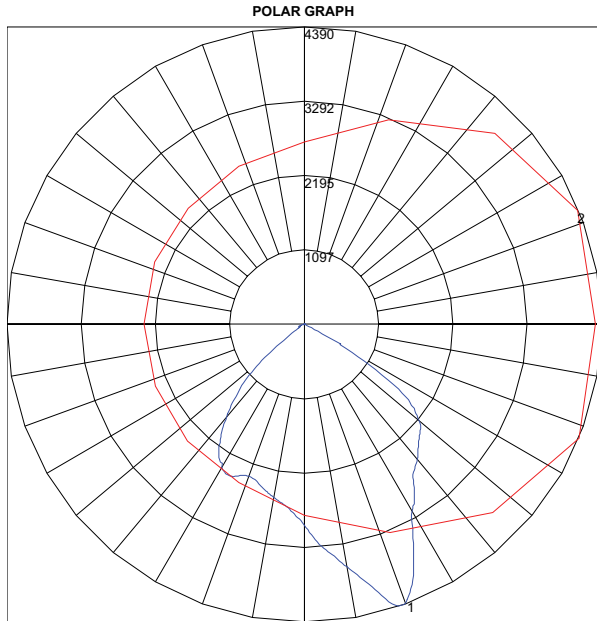

Maximum Candela = 4389.723 Located At Horizontal Angle = 337.5, Vertical Angle = 19
1 - Vertical Plane Through Horizontal Angles (337.5 - 157.5) (Through Max. Cd.)
2 - Horizontal Cone Through Vertical Angle (19) (Through Max. Cd.)

Isoillumination Diagram

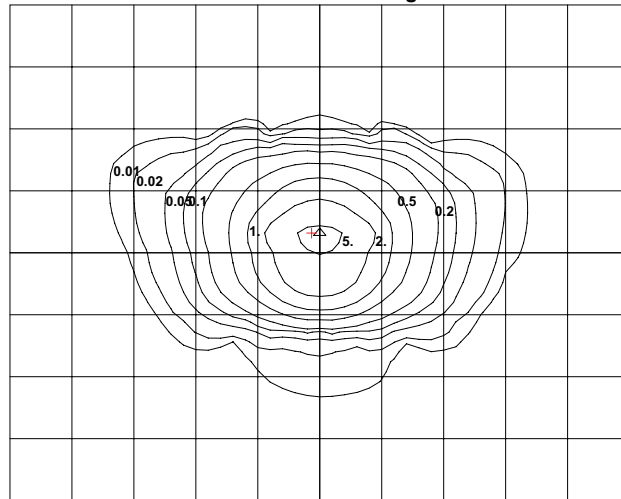

Mounting Height	Multiplier
10	5.760
15	2.560
20	1.440
25	0.922
30	0.640
35	0.470
40	0.360
45	0.284
50	0.230

Mounting Height = 24'. Each box is one mounting height.

ORDERING GUIDE

AWL2	-	LED80	-		-		-	
				VOLTAGE		COLOR TEMP		FINISH
				B - 120 - 277V*		5K - 5000K*		BRZ - BRONZE*
				A - 120V		4K - 4000K		CC - CUSTOM
				F - 277V		3K - 3000K		COLOR
								OPTIONS
								V - Visor
								WG - Wire Guard
								PCL - Polycarbonate Lens
								DMS - Dimmable Sensor
								SMS - On/Off Sensor
								PCA - 120V Photocell**
								PCF - 277V Photocell**

* Standard configuration

** Chosen photocell option must be the same as voltage